



Leading Optical Innovations

The Last 100 Meters

Optimized Drop Cables for FTTH

Lisa A. Dixon

October 2004



OFS Copyright © 2004 Furukawa Electric
North America Inc. All rights reserved.

Cable for an FTTH Network

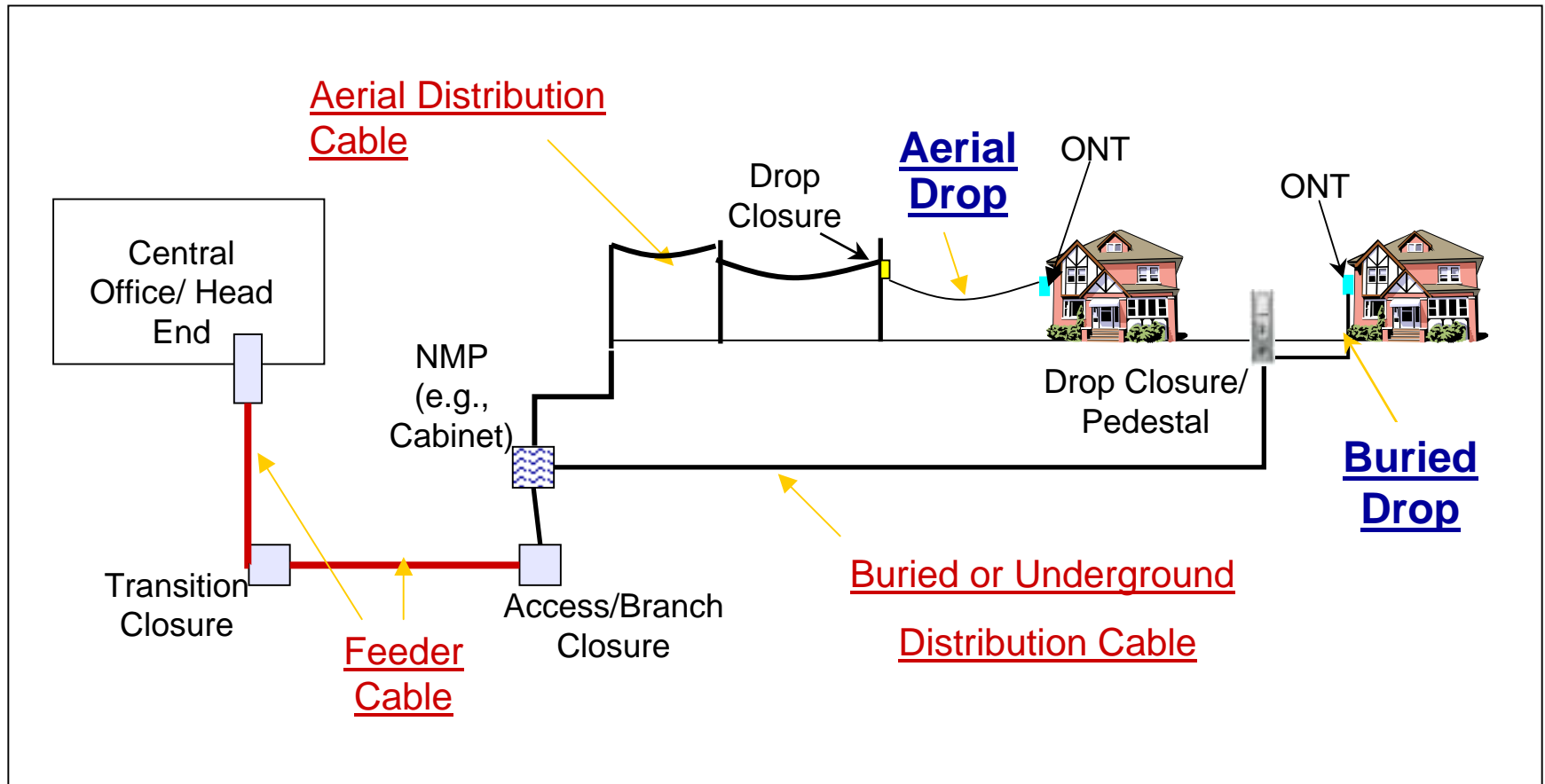

Overview

- **Drop Cables: Yesterday and Today**
- **Choosing a Cable**
 - How will it be installed?
 - Who's going to install it and terminate it?
- **Cable Options for your FTTH installation**
 - **Below-Grade**
 - Armored
 - Locatable
 - Microduct
 - **Aerial**
 - All-Dielectric
 - Metallic
- **To Preconnectorize... or Not**

“Drop Cables” of the 1990’s

- ❑ '90's Drop Cables: Significantly smaller than standard cables with 12 or fewer fibers

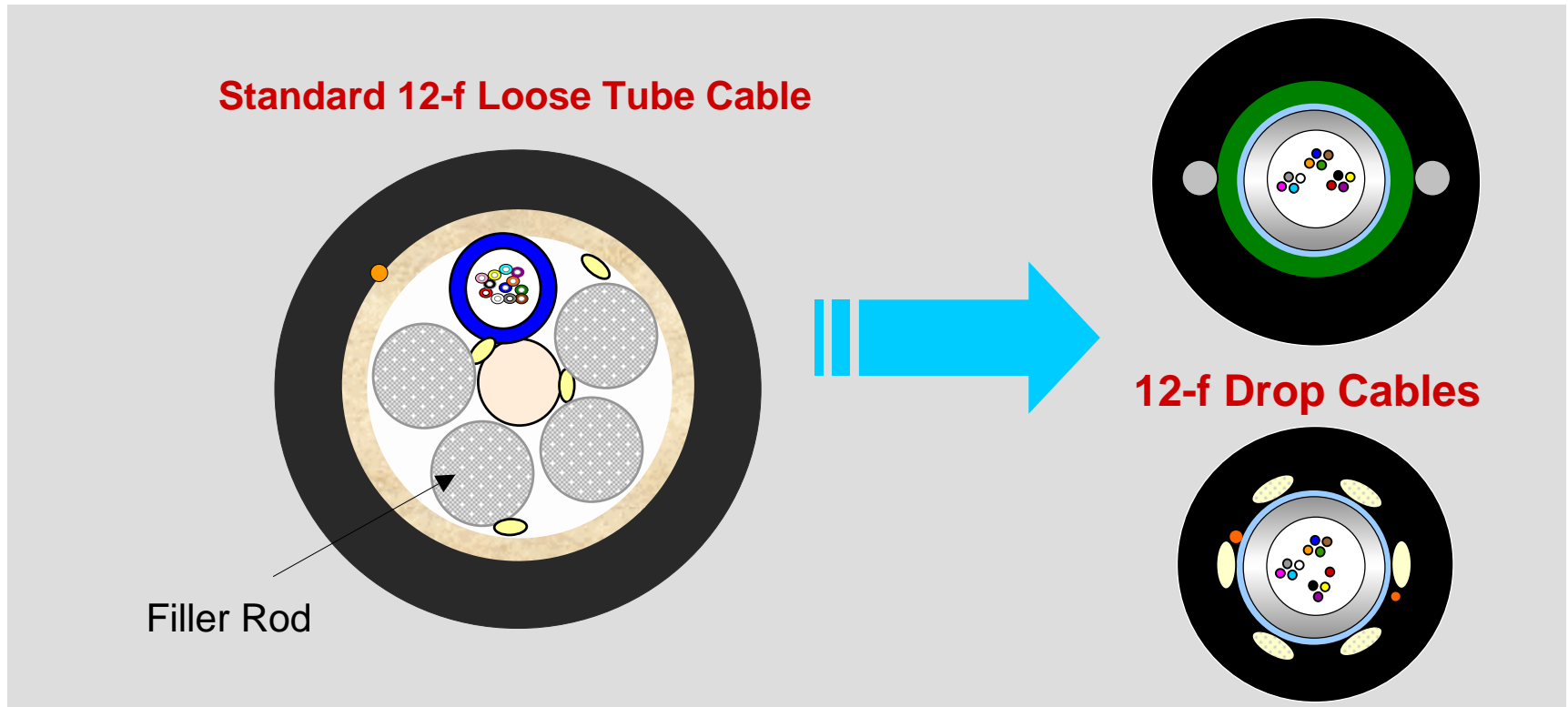

- ❑ In general, '90's Drop Cables were NOT used for FTTH:
 - Low-density networks (rural areas)
 - Mini distribution cables

FTTH Today....

“WANTED: Single Fiber Cable”

- **Should it be one of these?**

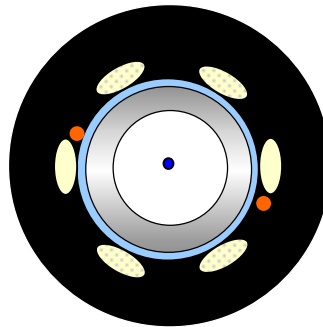
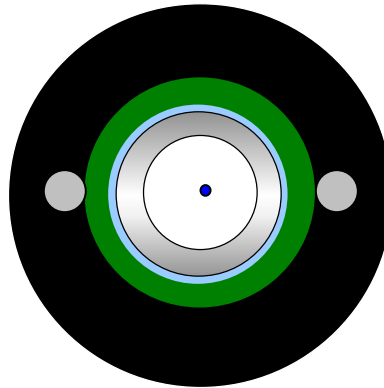

**...it depends, and
now there are more
choices!**

FTTH Today....

Criteria for Choosing Drop Cable

- Choose and plan carefully...

Aerial
Drop

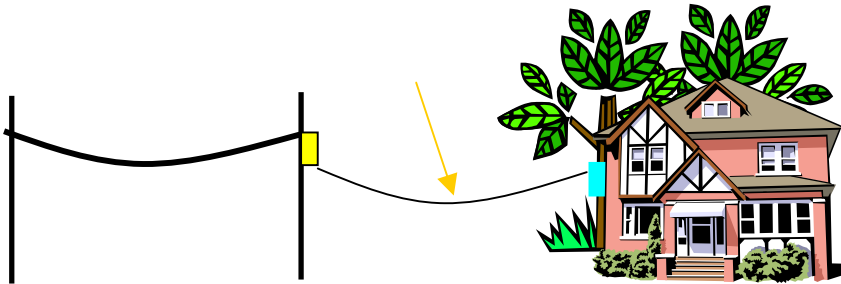

Buried
Drop



...your choice will affect the cost to connect every home!

Choosing Drop Cable: How are you going to install it?

▪ Below Grade

- Direct buried?
- In Duct?

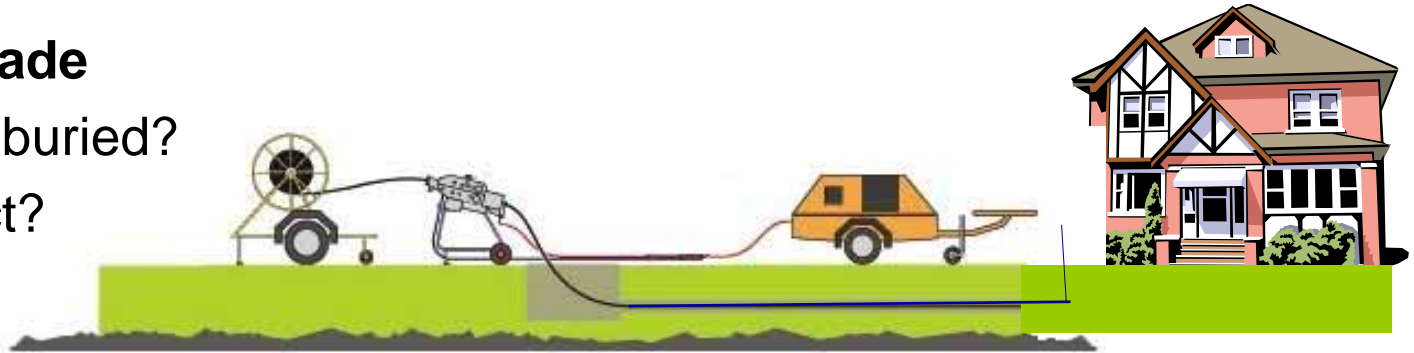

▪ Aerial

- Self-support?
- Lashed?

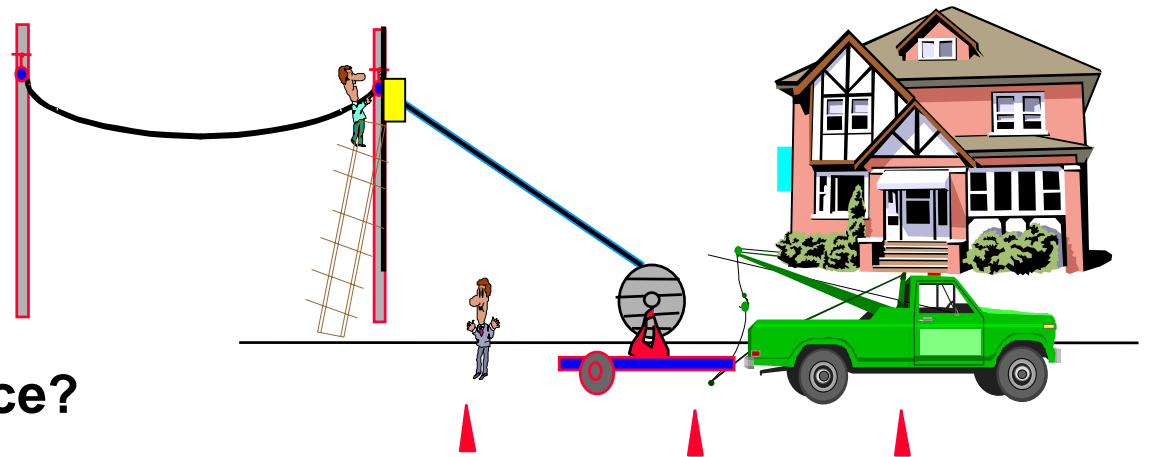

▪ Do you have a choice?

Choosing Drop Cable: Below-Grade Installations

❑ Why? Hide the cable!



Greenfield allows pre-installation of cable

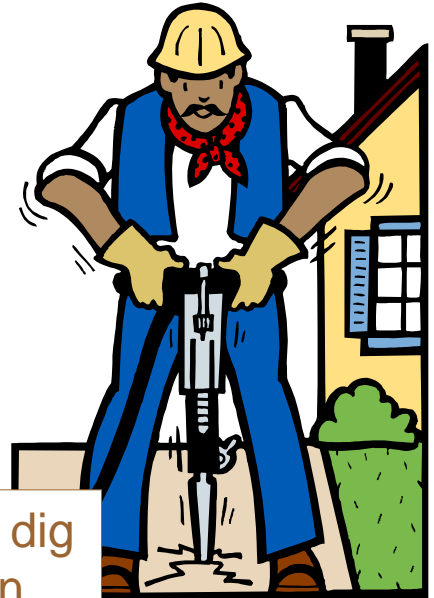

Brownfield requires dig up and restoration

❑ Use of conduit is an option:

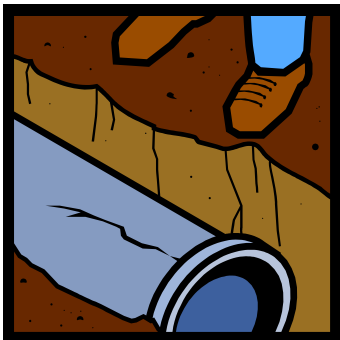

- **Greenfield** Pre-installed conduit allows “fiber on demand”
 - Avoid exposure of fiber to construction dig-up hazards
 - Install fiber “just in time” to deliver service
- **Brownfield** Conduit reduces dig up and restoration costs to repair damaged cable

Choosing Drop Cable: Below-Grade Installations

ARMORED DROPS

Key Product Attributes:

- Heavy Duty Drop Cable
- Resistance to Rodent Damage
- Locatable
- For Direct Buried and Duct Installations

Impact on Installation Costs:

- Minimize Accidental Dig-Ups

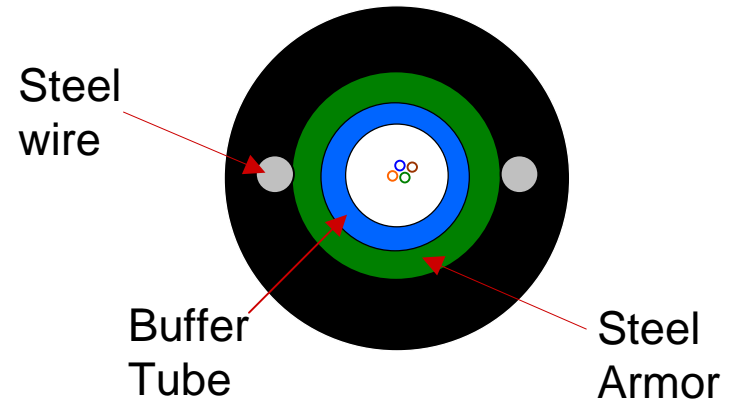

Disadvantages:

- Metal components must be grounded
- Robust armored sheath can be harder to remove
- Heavier and bulkier to ship, store, and handle
- Less flexible in routing and for coiling

Choosing Drop Cable: Below-Grade Installations

LOCATABLE DROPS

Key Product Attributes:

- Locatable
- Removable Metallic Component
- For Duct and Direct Buried Installations

Impact on Installation Costs:

- Minimize Accidental Dig-ups

Disadvantages:

- Metal components must be grounded
- Flat cables can be more difficult to coil

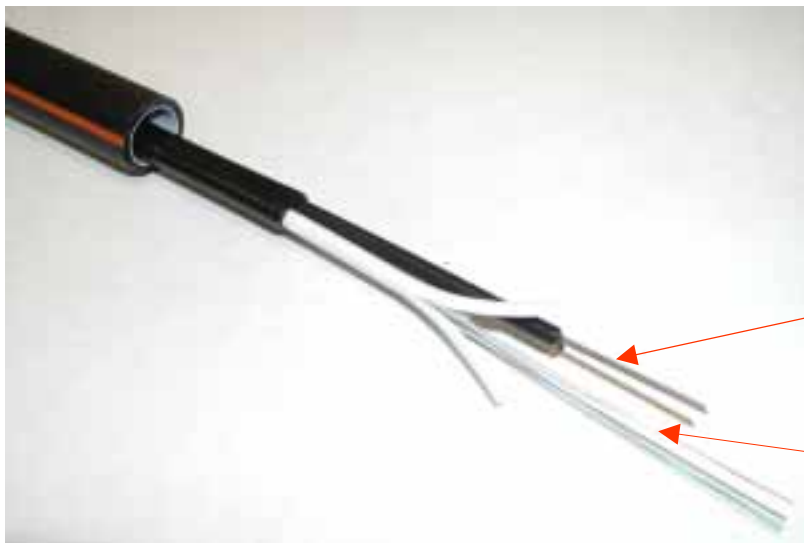

Metallic
Strength Wire

Buffered Fiber Unit

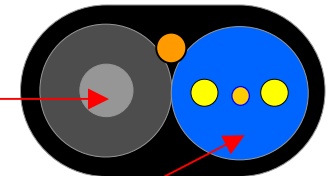

Choosing Drop Cable: Below-Grade Installations

Microduct Drops

Key Product Attributes:

- Smallest of Microcables!
- All-Dielectric
- For Microduct Installations

Impact on Installation Costs:

- Fast Installation
- Can Eliminate Splice at Each Premises
- Allow Fiber on Demand

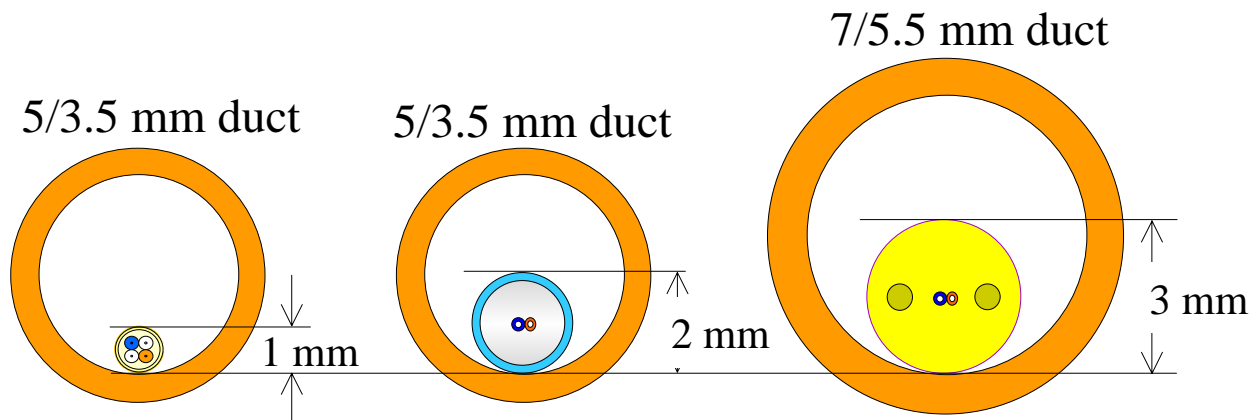
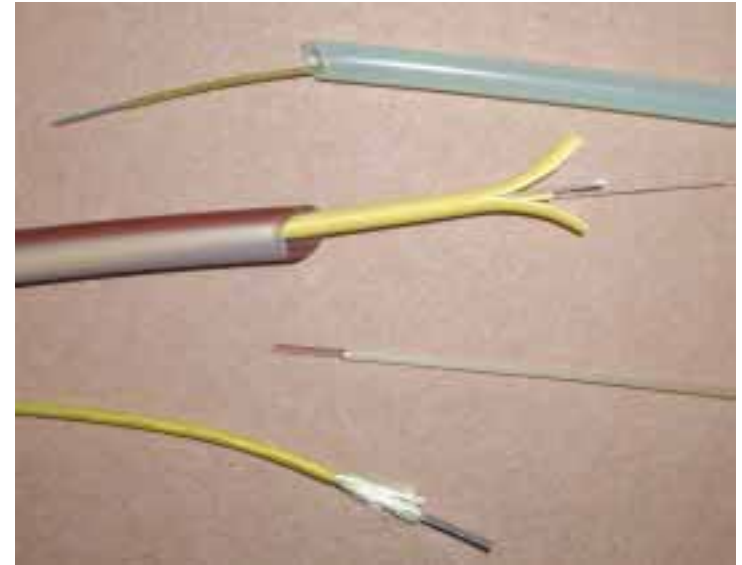

Choosing Drop Cable: Below-Grade Installations

Microduct Drops

ONT



NMP
(e.g.,
Cabinet)

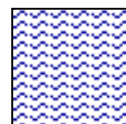

Disadvantages:

- Need complete network of duct to leverage benefits
- Must invest in equipment and training or experienced contractor

Choosing Drop Cable: Aerial Installations

- Why? **Fast! Lowest Restoration Cost!**

- Questions to Consider
 - Does community allow aerial utilities?
 - Are power utilities on the pole?
 - How long are the aerial spans?



Storm Loading Conditions will Affect Cable and
Installation Options

Choosing Drop Cable: Aerial Installations

ALL-DIELECTRIC SELF-SUPPORTING DROPS

Key Product Attributes:

- All-dielectric (no bonding or grounding)
- Self-supporting
- Compatible with copper drop hardware

Impact on Installation Costs:

- Simple, fast installation
- Inexpensive, standard hardware

Disadvantages:

- Flat cables can be more difficult to coil

Buffered Fiber Unit

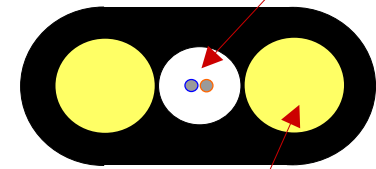

Dielectric Tensile Members

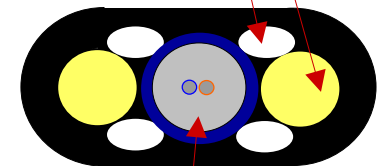

Fiber Buffer Tube



Choosing Drop Cable: Aerial Installations

METALLIC SELF-SUPPORTING DROPS

Key Product Attributes:

- Self-supporting
- Compatible with copper drop hardware

Impact on Installation Costs:

- Simple, fast installation
- Inexpensive, standard hardware

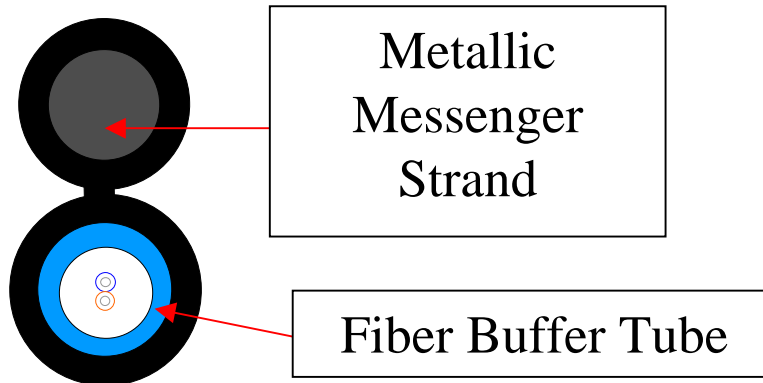

Disadvantages:

- Metal components must be grounded
- Not for use near power lines
- Flat cables can be more difficult to coil

Choosing Drop Cable: Who is going to terminate it?

- ❑ Fiber is not like copper
- ❑ Termination methods:
 - Fusion splicing
 - Field connectorization
 - Preconnectorized cables

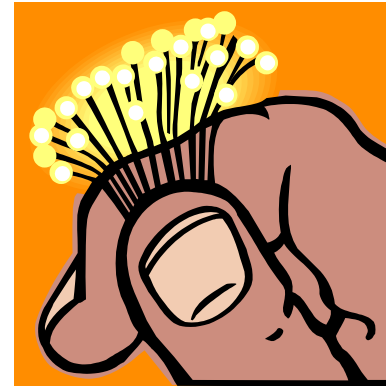

- ❑ Is your fiber to be terminated by....
 - A cable installation crew?
 - An experienced splicer?



**If you don't want to spend money
on a splicer,
...pre-connectorized cables
are an option.**



Choosing Drop Cable: Preconnectorized Cable

Key Product Attribute:

- Plug and Play Installation

Impact on Installation Costs:

- Simple, Fast Installation
- Reduce Craft Training
- Reduce Equipment and Tools Needed for Termination of Fiber

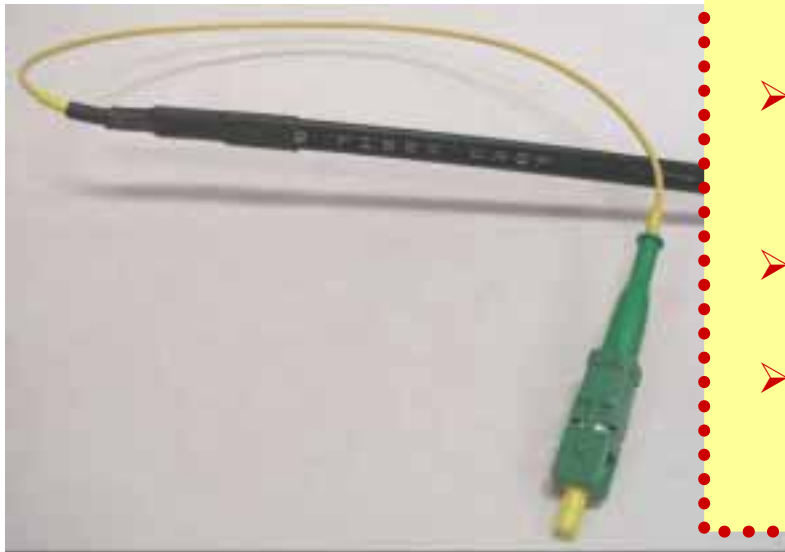
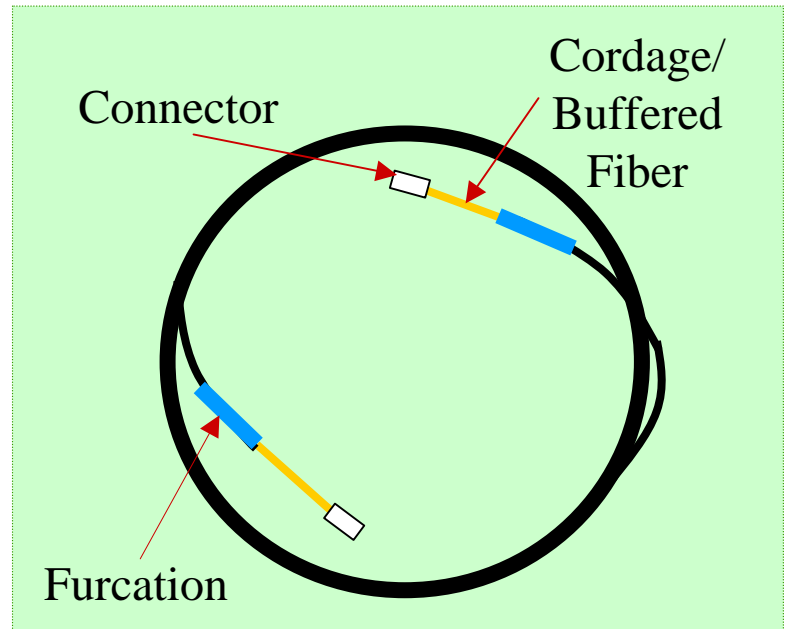

Considerations:

- Use of precon cables requires pre-engineering or options for slack storage
- Connectors must be protected during shipping, storage and installation
- Duct must be large enough for connector to be pulled through

Pre-Connectorized Cable Managing Slack Cable

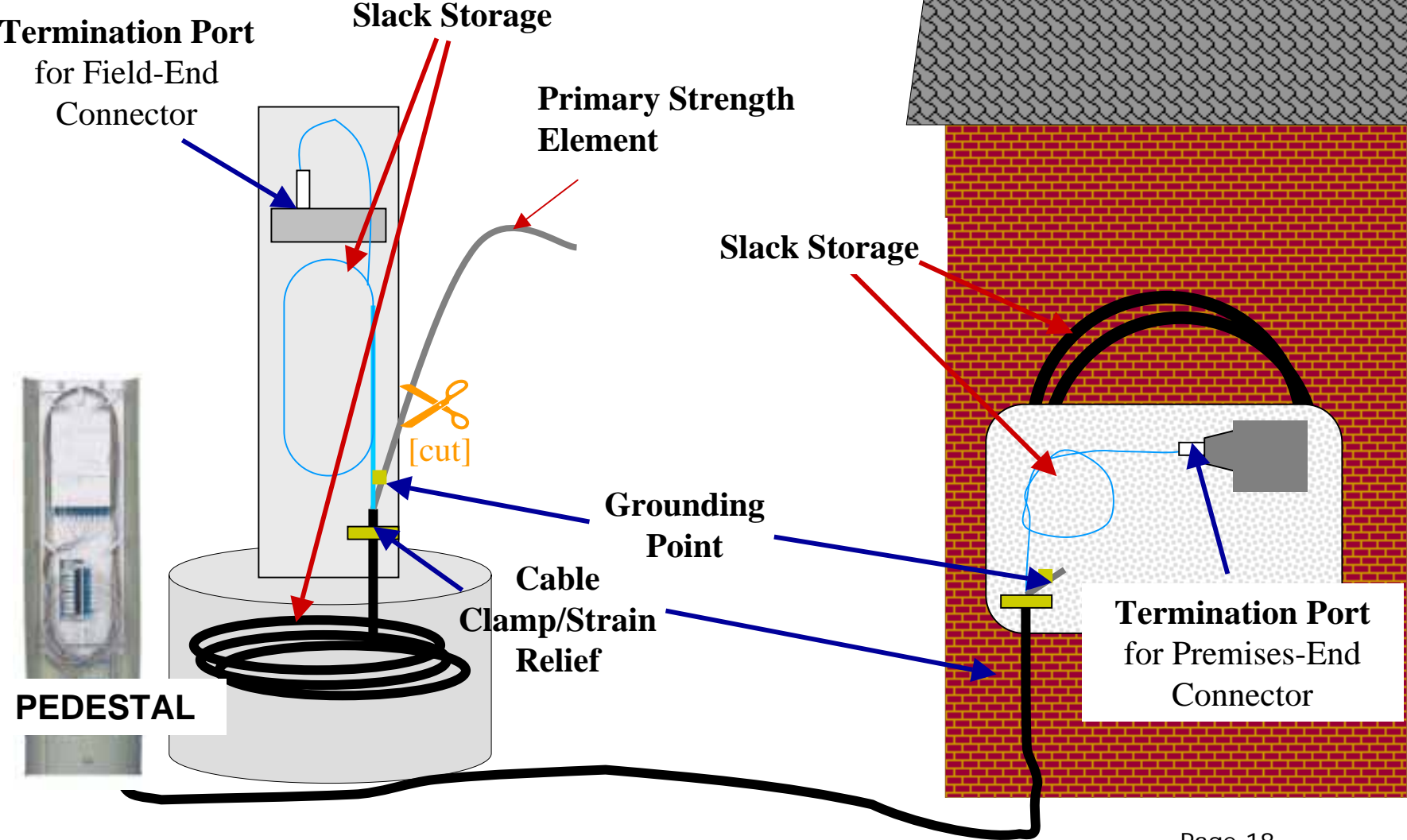

Questions to Answer Before Shopping For Cable:



- How many fibers are required to support the optical path to the customer?
- What type of termination is preferred? (fusion splicing, field connectorization, or preconnectorized drops)
- If the cable is to be installed aerially:
 - What is the maximum aerial span length needed to support your routes?
 - Can you use metallic aerial cables (i.e., how close are power cables)?
 - What kind of aerial hardware is required?
 - How expensive is it?
 - Can it be installed on the outside of a customer premises?
- If the cable is to be installed below-ground:
 - Are rodents a concern?
 - What type of equipment is available?
 - If installed in duct, what size duct is required for preconnectorized cable?
- Do the drop closures, pedestals, or enclosures fit (due to shape, size, or construction)?
- If the cable is metallic, is it compatible with the ONTs?

Conclusions:

- **Identify your constraints**
- **Review all options**
- **Find the best "fit"**
- **Plan ahead so you get the full benefit of your optimized cable choice!**